



Self-Propelled Telescopic Booms

S™-40 / S™-45

○ More of what
you need to
get the tough
jobs done.



S-40 / S-45

Standard Features

- S-40 has 46 ft (14 m) working height
- S-45 has 51 ft (15.5 m) working height
- S-40 has 31 ft 8 in (9.7 m) horizontal reach
- S-45 has 36 ft 8 in (11.2 m) horizontal reach
- 500 lb (227 kg) lift capacity
- Oscillating axle system on 4x4 models
- Dual fuel (Gas/LPG) or diesel engine options
- Fully proportional platform controls with ramp up/down feature
- Hydraulic platform rotation
- 360° continuous turntable rotation
- 12V DC auxiliary power
- Fuel select switch on platform and ground control panels (Gas/LPG models)

- Closed-loop hydrostatic drive
- Positive traction drive
- Drive enable system
- Self-leveling platform
- Locking turntable covers
- Anti-restart engine protection
- Auto engine fault shutdown
- Engine monitoring gauges
- AC wiring to platform
- Wire braided hose
- Tilt alarm
- Horn
- Hour meter

Range of Motion

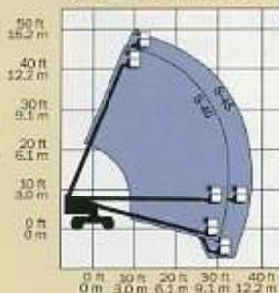

Options and Accessories

- Alarm package
- Cold start packages
- 2000 or 3000 watt AC generator
- 8 ft (2.44 m) steel platform
- Platform swing gate
- Air line to platform
- Platform rail pinch guard
- Platform work lights
- Lockable platform control box cover
- Tool tray
- Fluorescent tube caddy
- Hostile environment packages
- Steel turntable covers
- Hydraulic oil cooler
- Additional LPG tank
- GS/LPS rating for Ford engine powered machines
- Foam-filled tires
- Tow package
- Driving lights

Standards Compliance

- ANSI/SIA A92.5
- CAN3-B354.4-M82
- CE compliance option
- AS 1418.10

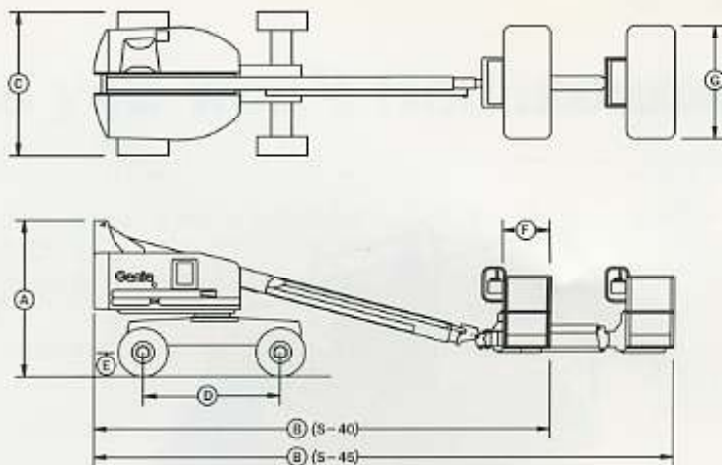

Specifications

Model	S-40		S-45	
	US	Metric	US	Metric
Working height max	46 ft	14 m	51 ft	15.5 m
Platform height max	40 ft	12.2 m	45 ft	13.7 m
(A) Height - stowed	8 ft 2 in	2.5 m	8 ft 2 in	2.5 m
(B) Length - stowed	23 ft 11 in	7.3 m	27 ft 10 in	8.5 m
(C) Width	7 ft 6 in	2.3 m	7 ft 6 in	2.3 m
(D) Wheelbase	7 ft 3 in	2.2 m	7 ft 3 in	2.2 m
(E) Ground clearance	12 1/2 in	32 cm	12 1/2 in	32 cm
(F) Platform length:	6 ft	30 in	30 in	76 cm
	8 ft	36 in	36 in	91 cm
(G) Platform width:	6 ft	72 in	72 in	1.83 m
	8 ft	96 in	96 in	2.44 m
Horizontal reach max	31 ft 8 in	9.7 m	36 ft 8 in	11.2 m
Lift capacity	500 lb	227 kg	500 lb	227 kg
Turning radius - outside	15 ft 8 in	4.78 m	15 ft 8 in	4.78 m
Turning radius - inside	6 ft 8 in	1.78 m	6 ft 8 in	1.78 m
Turntable rotation	360° continuous		360° continuous	
Turntable tailswing	34 in	86 cm	34 in	86 cm
Power source	Ford LRG 425 EFI Gas/LPG 82 hp (61 kw) Deutz Diesel 56 hp (42 kw) Deutz Diesel 36 hp (27 kw) Perkins Diesel 60 hp (45 kw)			
Platform rotation	160°	160°	160°	160°
Auxiliary power unit	12V DC		12V DC	
Tires - RT Lug	12-16.5 NHS		12-16.5 NHS	
Tires - Ribbed (4x2 front)	12.5 L-16 SL		12.5 L-16 SL	
Hydraulic tank capacity	45 gal	170 litre	45 gal	170 litre
Fuel tank capacity	33 gal	125 litre	33 gal	125 litre
Weight	11,650 lb	5,284 kg	14,790 lb	6,709 kg
S-40/S-45	4x2		4x4	
Drive speed, stowed Gas/LPG models	4 mph	6.4 km/h	3.5 mph	5.6 km/h
Drive speed, stowed Deutz Diesel models	3.8 mph	6.1 km/h	2.8 mph	4.5 km/h
Drive speed, raised or extended	0.68 mph	1.1 km/h	0.68 mph	1.1 km/h
Gradeability - stowed	30%		40%	

Distributed By:

Genie Industries

GENIE UNITED STATES

18340 NE 76th Street
P.O. Box 97030
Redmond, Washington 98073-9730
Telephone (425) 881-1800
Toll Free in USA/Canada 800-536-1800
Fax (425) 883-3475
<http://www.genielift.com>

GENIE UNITED KINGDOM

Brunel Drive, Newark
Nottinghamshire NG24 2EG
England
Telephone (44) 01636-614700
Fax (44) 01636-611090
<http://www.genielift.com>